

DE	Übersicht Verstärkungsprofil und Verbindungsplatte für Möbeloberboden
FR	Aperçu général du profil de renforcement et de la plaque de raccordement pour élément
EN	Overview of the reinforcement profile and connecting plate for cabinet tops
IT	Panoramica profilo di rinforzo e piastra di collegamento cielo mobile
ES	Vista de conjunto perfil de refuerzo y pletina de unión para la tapa superior del mueble

- DE** Möbeloberboden bei Doppelanlagen ohne Mittelwand muss verstärkt werden!
- FR** Dans le cas d'installations doubles sans cloison centrale, les éléments supérieurs de meuble doivent être renforcés !
- DE** The cabinet top on double systems without a centre panel must be reinforced!
- DE** I cieli dei mobili con sistemi doppi senza parete centrale vanno rinforzati!
- DE** Es imprescindible reforzar el techo del mueble en instalaciones dobles sin panel central!

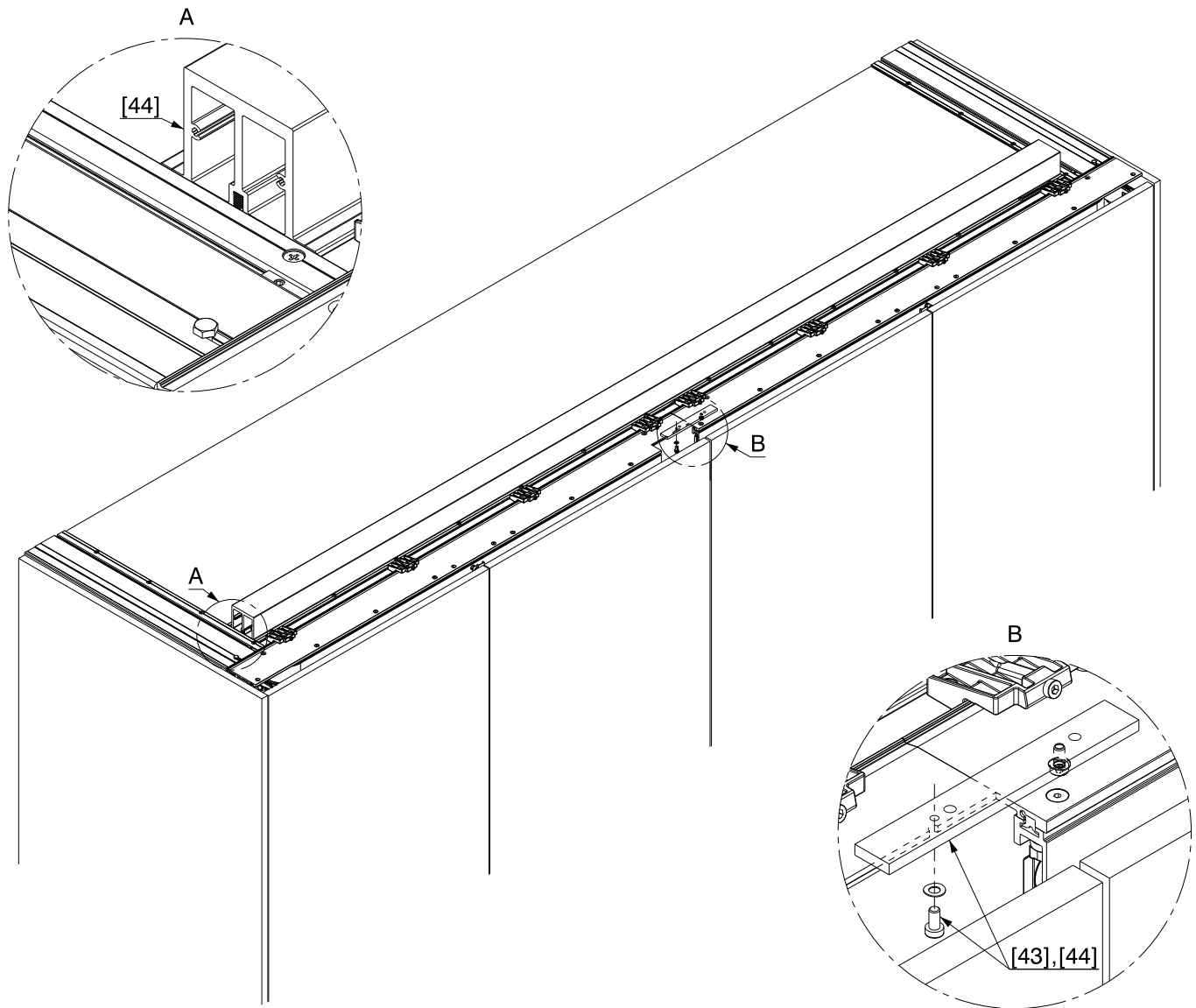

[43]		24321	[44]		24322
------	--	-------	------	--	-------

■ DE Hawa Teile / FR Éléments Hawa / EN Hawa Components / IT Componenti Hawa / ES Componentes Hawa

DE Es gelten metrische Abmessungen – Abmessungen in Zollangaben sind nur zur Information.
EN Metric Dimensions are valid - dimensions stated in inches are for information only.

DE	Ausrichten des Schrankes
FR	Ajustement de l'armoire
EN	Aligning the cabinet
IT	Allineamento armadio
ES	Alineación del mueble

- DE** Der Schrank muss nivelliert und an den Baukörper (Boden, Wand, Decke) geschraubt werden!
- FR** L'armoire doit être mise à niveau et vissée sur le corps de bâtiment (sol, mur, plafond) !
- EN** The cabinet must be levelled and screwed to the building (floor, wall or ceiling)!
- IT** L'armadio deve essere livellato e fissato con viti al corpo edilizio (pavimento, parete, soffitto)!
- ES** Es imprescindible nivelar el armario y atornillarlo (al suelo, pared, techo)!

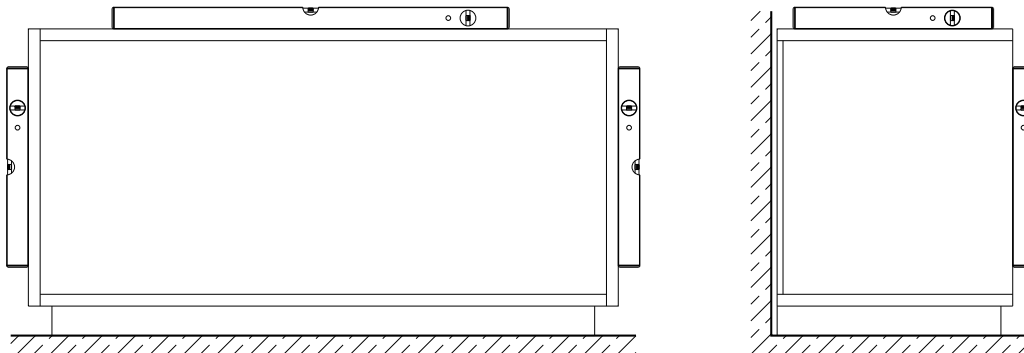

DE	Montage Verbindungsplatte
FR	Montage de la plaque de raccordement
EN	Fitting the connecting plate
IT	Montaggio piastra di collegamento
ES	Instalación de la pletina de unión

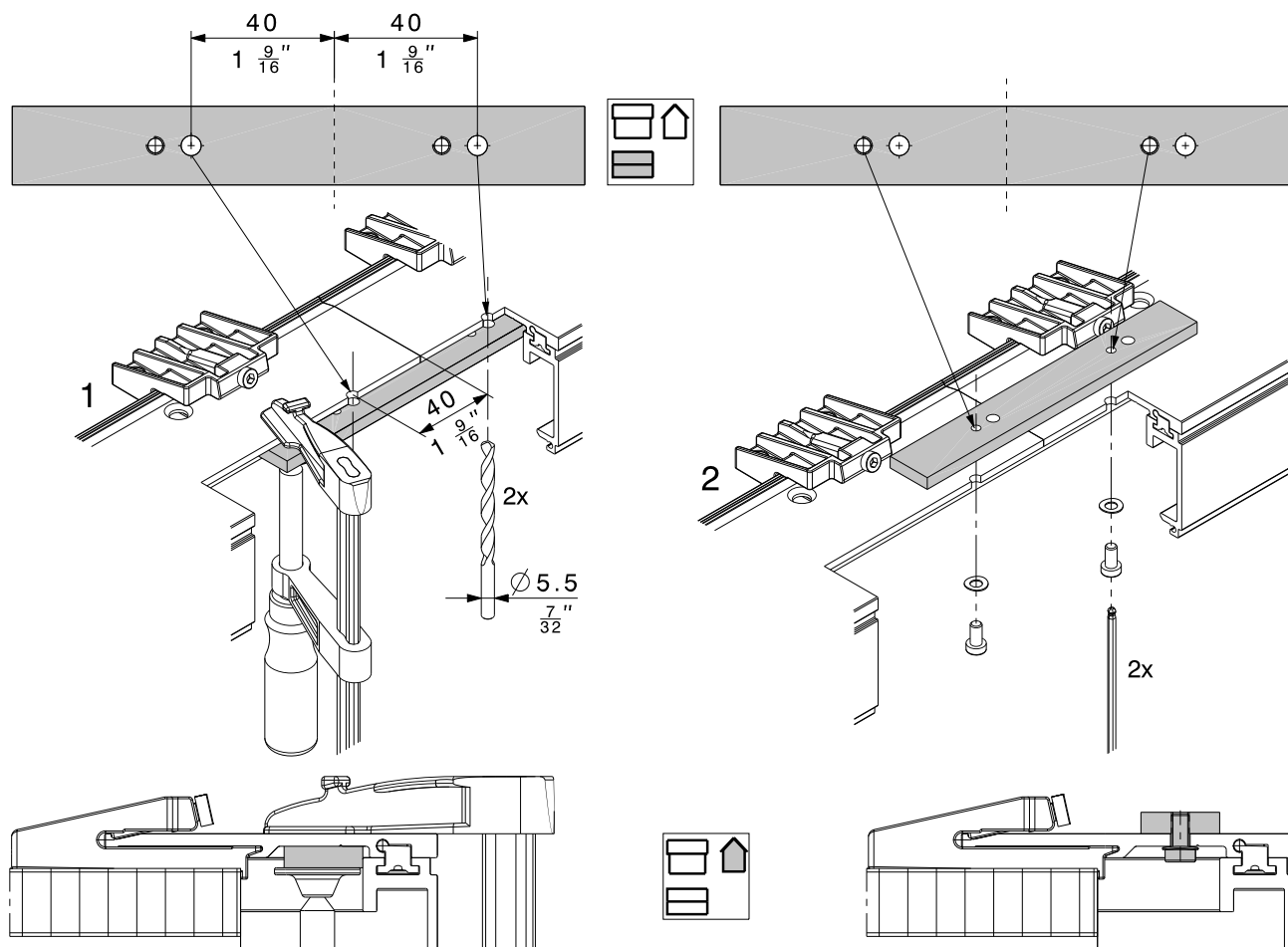

- DE** Montage Verstärkungsprofil Möbeloberboden
- FR** Montage du profil de renforcement pour élément supérieur de meuble
- EN** Fitting the cabinet top reinforcement profile
- IT** Montaggio profilo di rinforzo cielo mobile
- ES** Instalación del perfil de refuerzo de la tapa superior del mueble

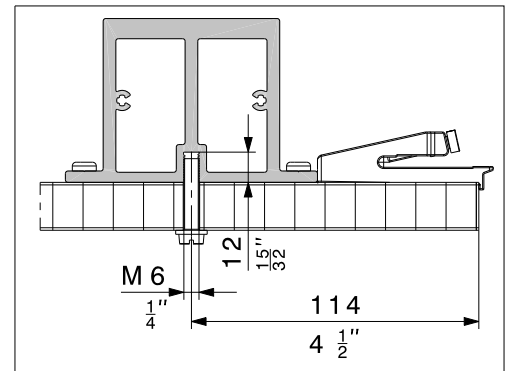
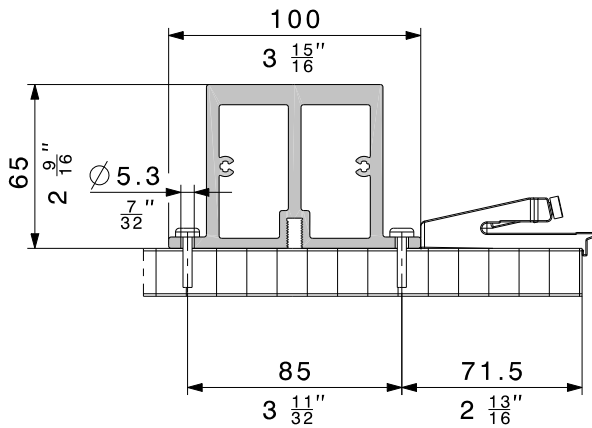
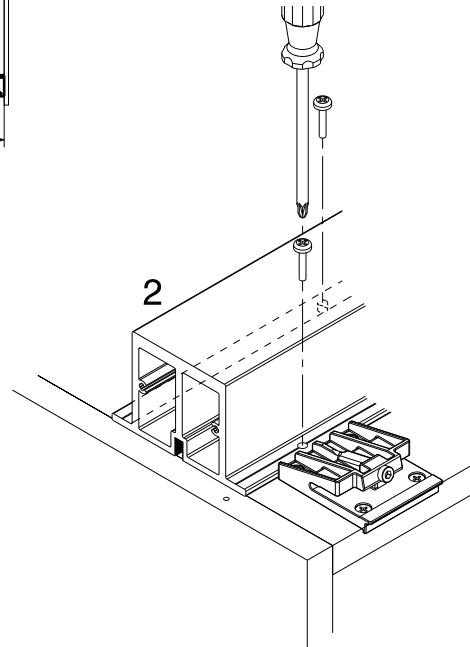
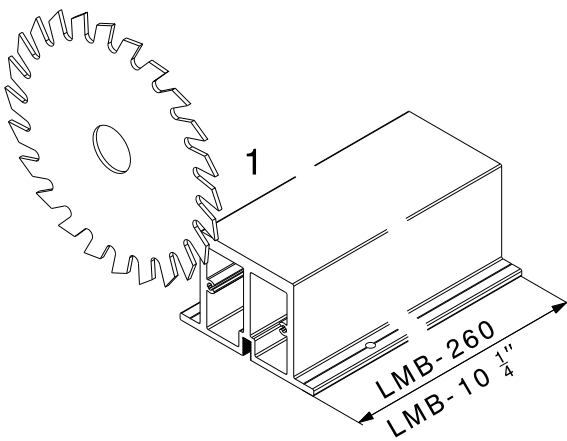
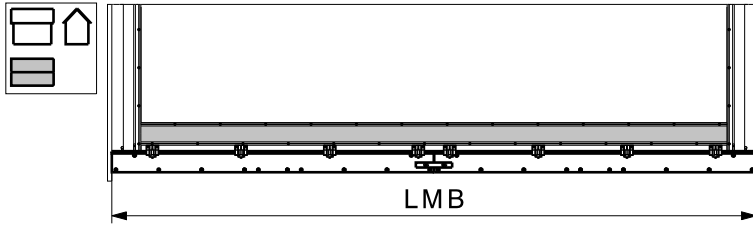
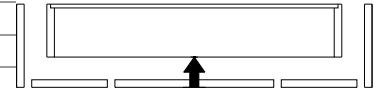

DE	Möbeloberboden ausrichten
FR	Ajustement de l'élément supérieur de meuble
EN	Aligning the cabinet top
IT	Allineamento cielo mobile
ES	Alinear la tapa superior del mueble

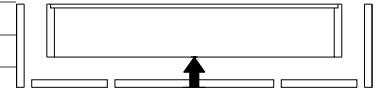

- 🔧 DE** Die nachfolgenden Abbildungen und Messung M verstehen sich mit geschlossenen Türen.
FR Les illustrations ci-dessous et la mesure M s'entendent avec portes fermées.
EN The following illustrations and the dimension M apply when the doors are closed.
IT Le seguenti illustrazioni e quote M si intendono con ante chiuse.
ES Las figuras y mediciones M siguientes se entienden con las puertas cerradas y con las juntas alineadas.

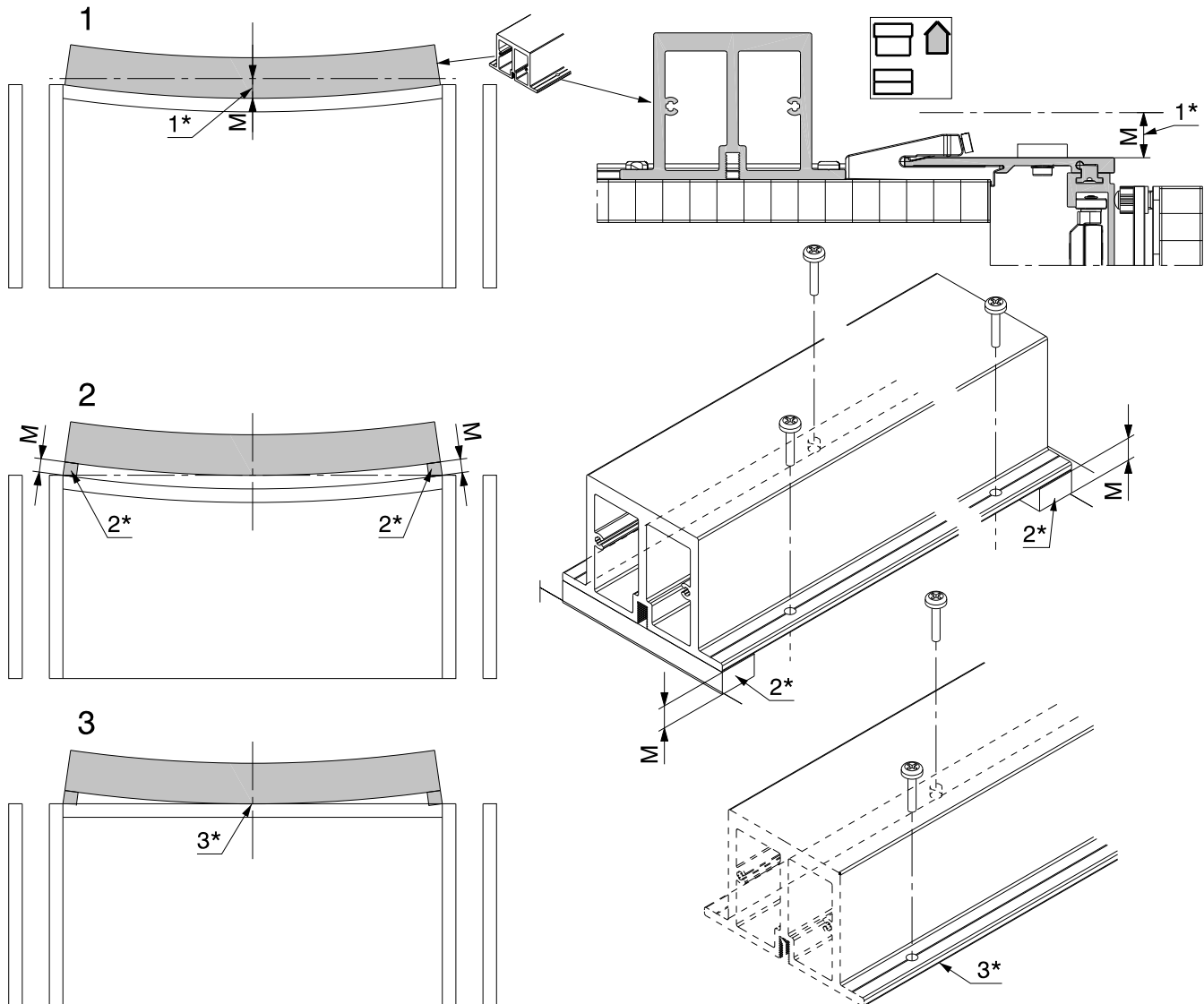

- 1*** **DE** Distanz M messen / **FR** Mesurer la distance M / **EN** Measure distance M / **IT** Misurare la distanza M / **ES** Medir la distancia M
2* **DE** bauseits / **FR** incombant au client / **EN** provided by customer / **IT** da parte del committente / **ES** a suministrar por el cliente
3* **DE** Maximale Durchbiegung des Möbeloberbodens 2 mm / **FR** Infléchissement maximal de l'élément supérieur de meuble de 2 mm / **EN** Maximum deflection of the cabinet top: 2 mm ($\frac{3}{16}$ ") / **IT** Flessione massima cielo mobile: 2 mm / **ES** Curvatura máxima de la tapa superior del mueble 2 mm